

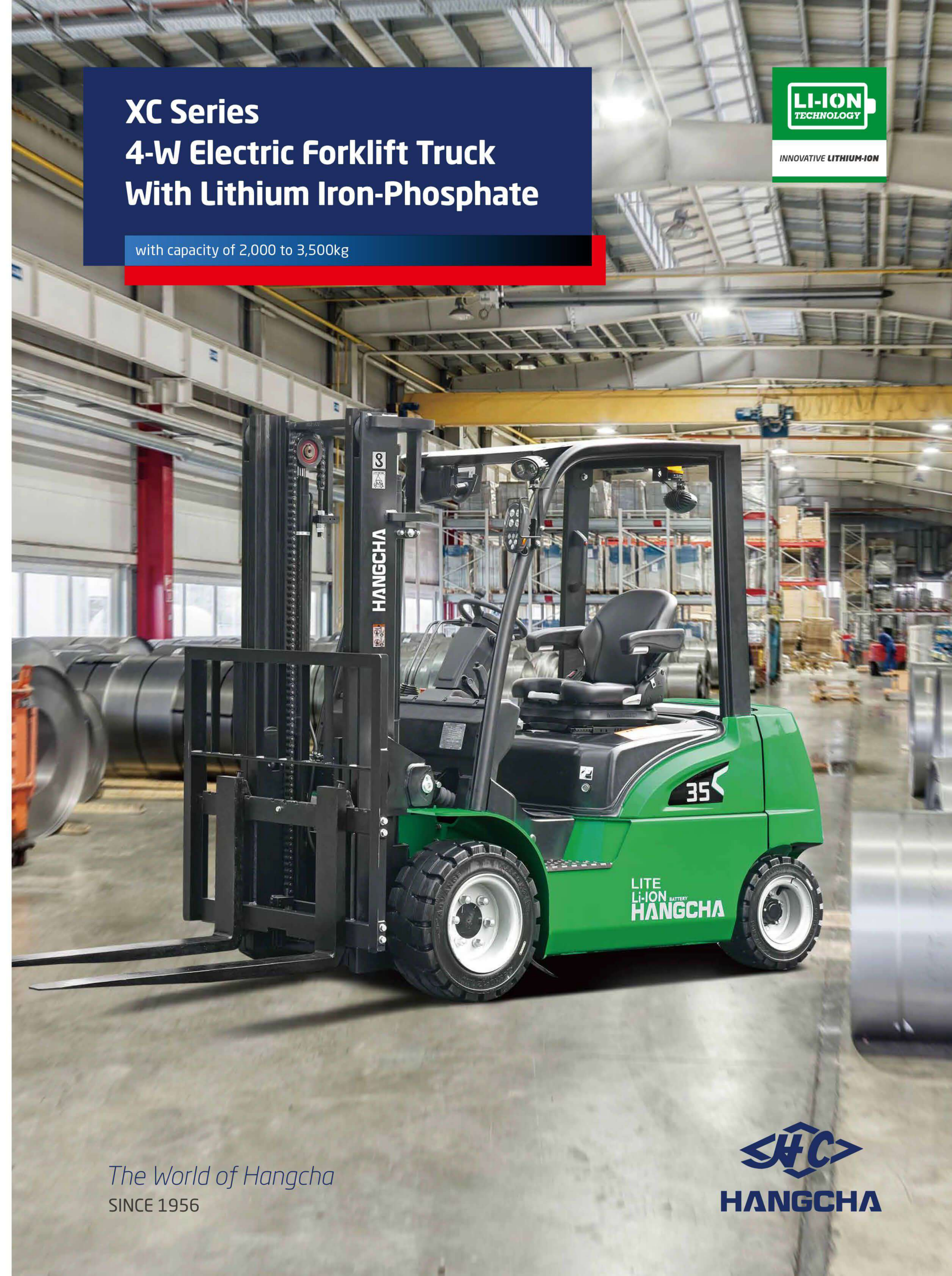

XC Series 4-W Electric Forklift Truck With Lithium Iron-Phosphate

with capacity of 2,000 to 3,500kg



Sogema Group s.r.l.

46037 Roncoferraro (Mn)

Tel: +39 0376/270758

shop@sogemastore.it
www.sogemastore.it
www.sogemagroup.it



Folgen Sie uns auf
Instagram



Folgen Sie uns auf
Facebook



Folgen Sie uns auf
YouTube



"Hangcha Forklift"
App herunterladen



ISO14001
ISO14001:2015



ISO9001
ISO9001:2015



HANGCHA trucks conform
to the European Safety
Requirements.

2024 VERSION 1/COPYRIGHT 2024/03

HANGCHA Group Co., LTD behält sich das Recht vor, Änderungen bezgl. Farbe, Spezifikationen, Ausstattung und sonstige Details, dierer Bröschüre ohne Vorankündigung vorzunehmen. Fahrzeugfarben können von den Farben in dieser Brochure abweichen.

The World of Hangcha
SINCE 1956



INNOVATIVE SOLUTIONS NEW POWER NOW



The XC series new energy electric forklifts, covering range from 2.0t to 3.5t, is a series of products with new chassis launched by HANGCHA.

Innovative, reliable lithium-ion technology, which are developed jointly by HANGCHA and CATL. Battery cells and modules are from CATL, with reliable quality, exclusively for HANGCHA.

Rapid charging and opportunity charging ensure continuous availability of trucks. Lightweight design, flexible, high level of energy efficiency, maintenance-free, long service life.

Hangcha battery packs

Battery capacity (kW·h)		
Pack1	2.0 - 2.5t	76.8V*230Ah, 17.66Kwh
Pack2	2.0 - 2.5t	76.8V*304Ah, 23.34Kwh
Pack3	2.0 - 2.5t	76.8V*460Ah, 35.32Kwh
Pack4	3.0 - 3.5t	76.8V*304Ah, 23.34Kwh
Pack5	3.0 - 3.5t	76.8V*460Ah, 35.32Kwh
Pack6	3.0 - 3.5t	76.8V*560Ah, 43.00Kwh



High capacity CATL battery packs

Integrated Battery Management System (BMS) continually monitors energy management and ensures reliable operation. HANGCHA provides Li-Ion battery with 5 years or 10000 hours warranty.

Battery capacity (kW·h)		
Pack1	2.0 - 2.5t	80V*228Ah, 18.24Kwh
Pack2	3.0 - 3.5t	80V*302Ah, 24.16Kwh
Pack3	2.0 - 2.5t	80V*302Ah, 24.16Kwh
Pack4	2.0 - 2.5t	80V*456Ah, 36.48Kwh
Pack5	3.0 - 3.5t	80V*456Ah, 36.48Kwh
Pack6	3.0 - 3.5t	80V*604Ah, 48.32Kwh

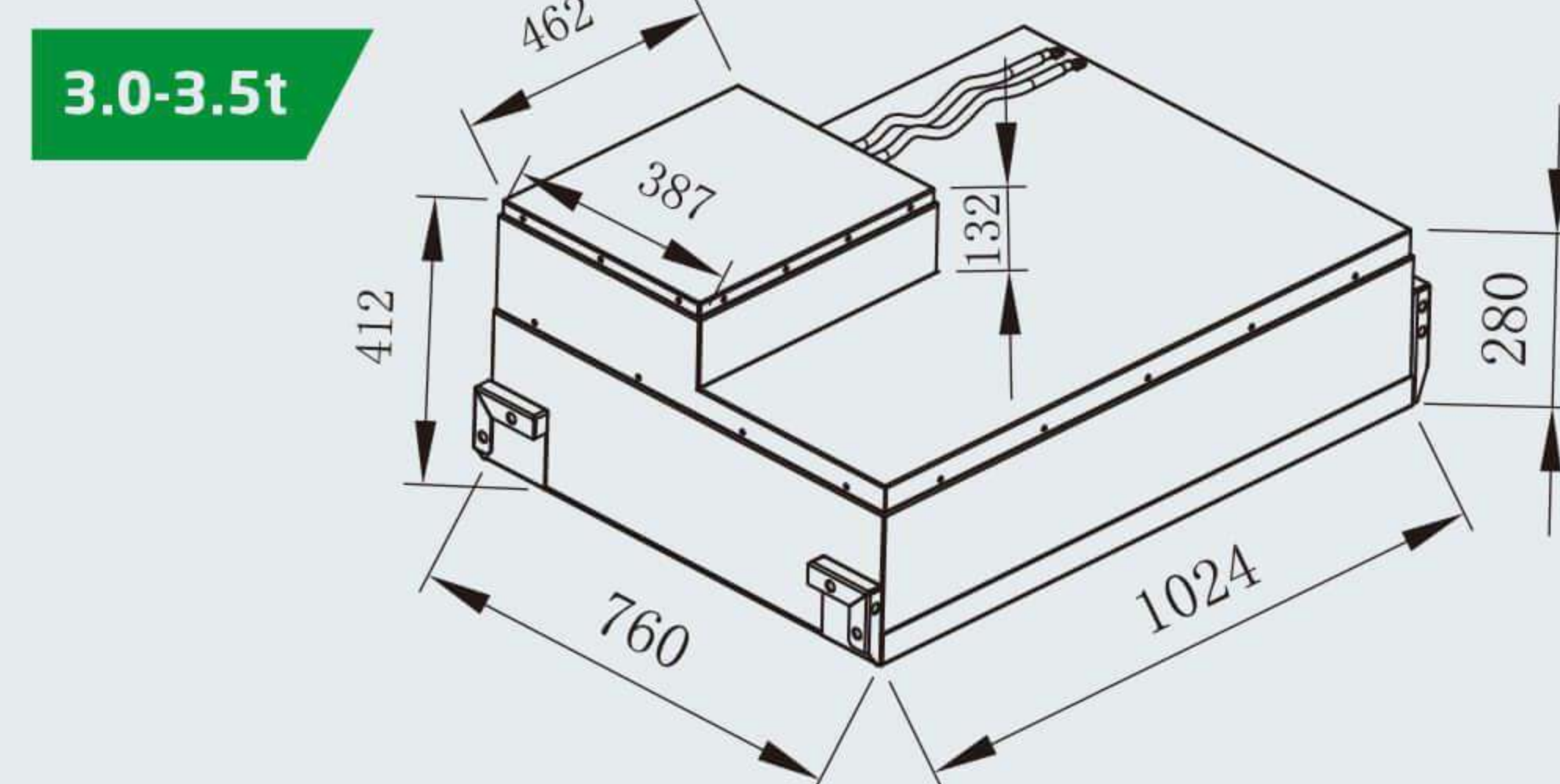
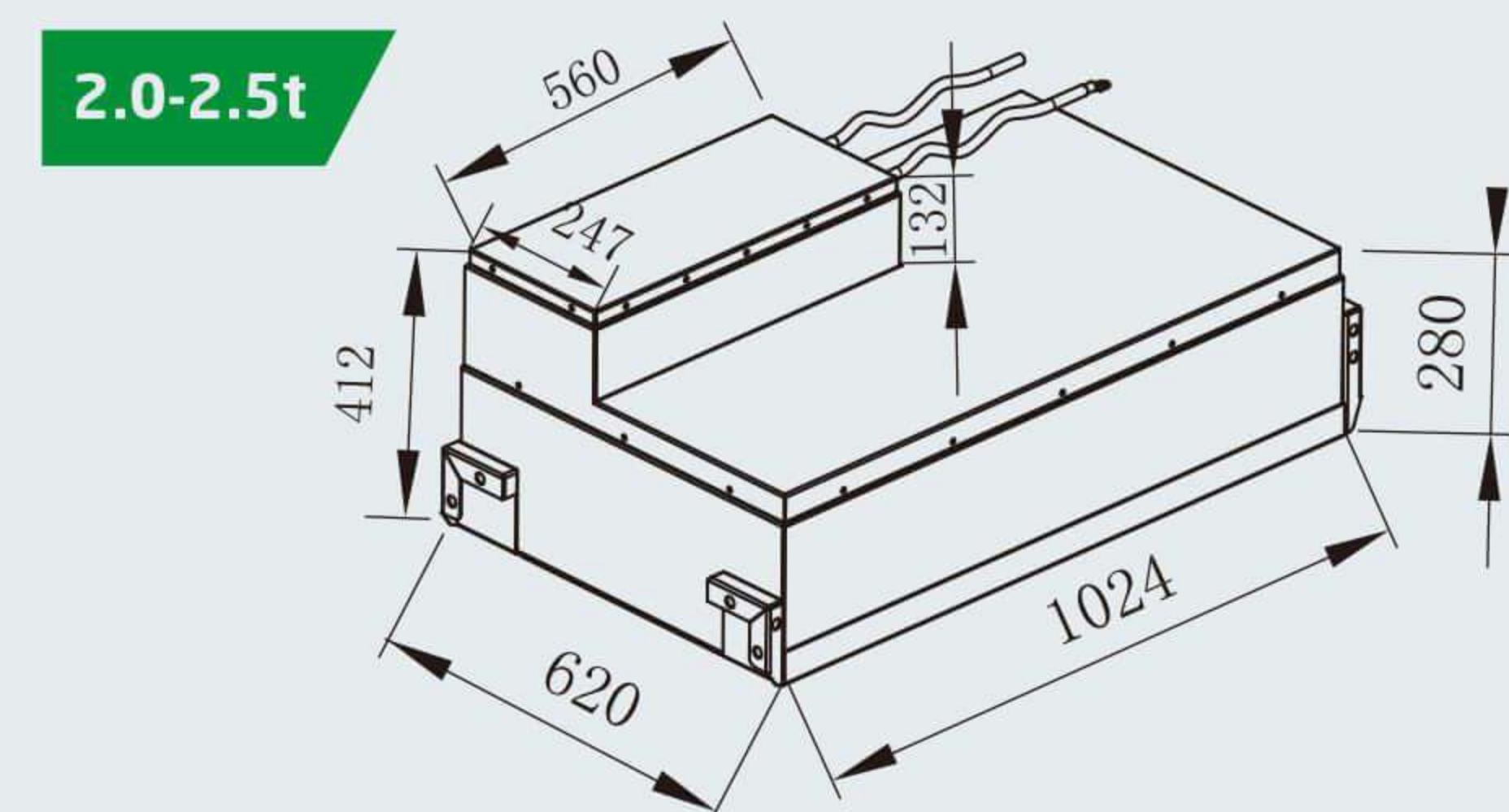

Excellent Ergonomic Design

- / The truck has a large operating space more than **50%** larger than the traditional electric truck.
- / The dashboard in the driver's cab is placed overhead and can be seen when the driver lifts her/his head, and the function buttons can be pressed easily.
- / For the optional integrated fingertip control system, the combined operating armrest integrates the emergency cut-off, horn and quadruple thumb switches, etc., is electrically controlled through the CAN bus and is highly reliable.
- / The enlarged brake pedal and appropriate regenerative braking function can effectively reduce the driver's fatigue.



Advantages



The rear axle is provided with a flexible suspension system (for standard configuration and automatic deceleration at turns improve the driver's comfort.

The high-frequency MOSFET integrated controller ensures smooth and accurate driving and lifting control, and has excellent speed regulation performance, good performance of electronic control matching the motor, functions of regenerative braking, reverse braking and anti-sliding on ramps, etc., and high safety and reliability.

The ultra-high power AC traction motor has a bridge structure. An ultra-high power AC pump motor is used. The system has high efficiency, complete protection functions, built-in speed and temperature sensors, and greatly improved reliability and life.

**RELIABLE
TRUCKS**



**6 YEARS
WARRANTY**

Easy operations and maintenance

Internal Components Protected with Fully-sealed Hood, controllers, motors electrical components, etc. are sealed from dust and water.

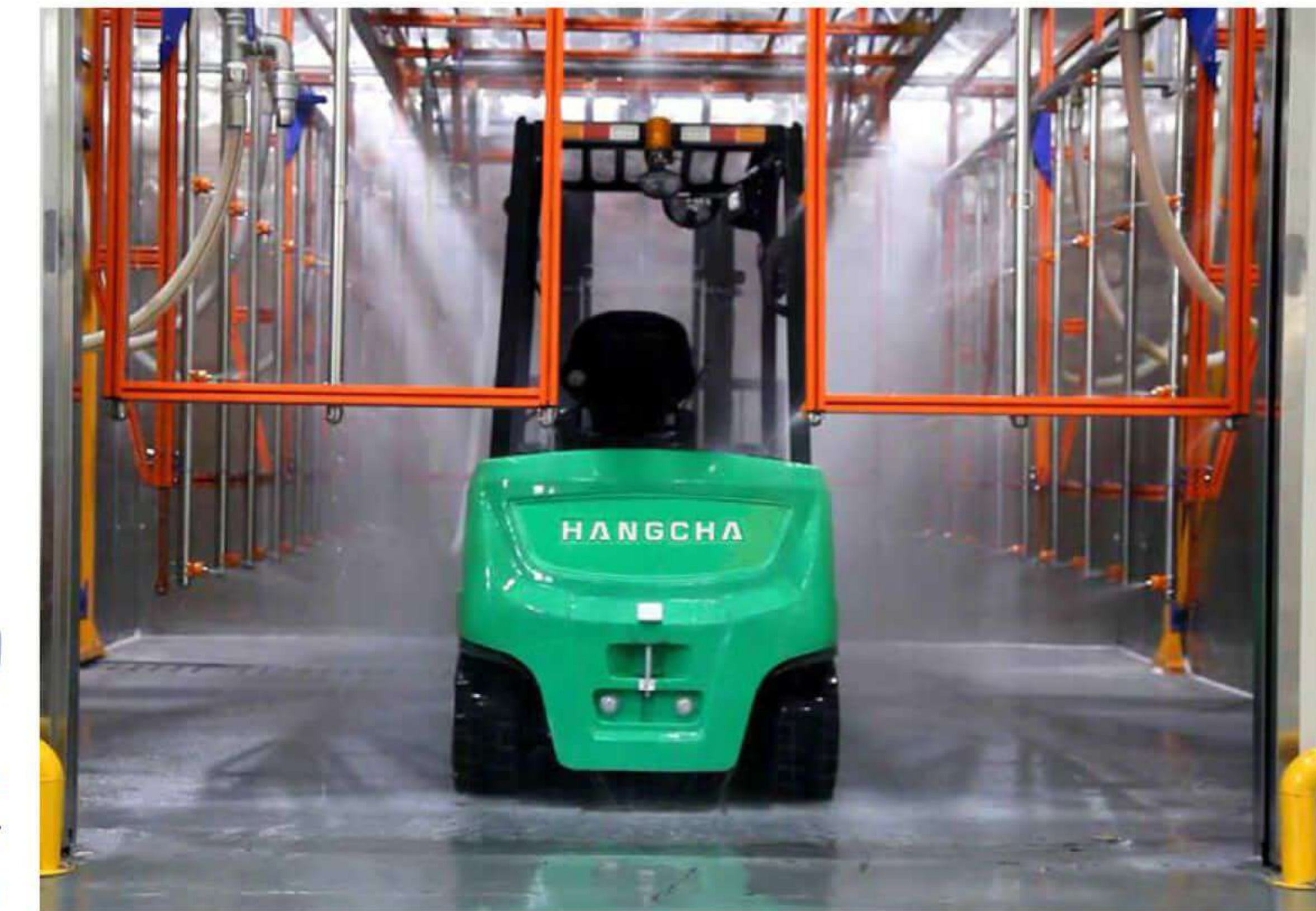

IPX4 water resistance rating, suitable for outdoor operation



The hood can be opened at a large angle facilitating the maintenance.





Safety

The optional OPS system can disable the lowering when the driver leaves the seat and enable high safety.

The standard configuration provides soft landing system. In addition, an optional lift buffering system is provided to protect the goods from falling and damaging the ground.

The handbrake can be optionally equipped with an alarm buzzer to prompt the driver to pull up the handbrake before leaving the truck.



Three horn buttons are provided, which are respectively on the driver's steering wheel, thumb switch equipped armrest (optional) and reverse armrest (optional), for alerting and protecting the surrounding people.



A PIN code should be provided before entering the system. 99 sets of PIN codes are available for the administrator. The truck is highly secured and irrelevant personnel cannot start the truck.



IP67 Protection Rating



Quick charge < 2.0h

Main Accessories

The main electrical components such as the controller, contactor, power plug, emergency cut-off switch, dashboard, accelerator, are all products of well-known world brands.

The emergency cut-off switch equipped for the standard configuration complies with EU regulations.

The truck has passed the CE certification.



Comfort

Owing to the low center of gravity and good stability, the driver feels comfortable during turning.

The ergonomically designed adjustable steering wheel makes the driver feel good. The seat can be adjusted back and forth by 210mm. The operator can choose the best driving position.

New designed mast increases the wide view by 15%.

With friendly human-computer interfaces, the 4.33" True Color Screen instruments have good visibility and clear readings.

Silence, no pollution, energy saving and other advantages meet the environmental protection requirements.



Grammer fingertip (Optional)

Options

- / Lithium packs that can be replaced quickly
- / Pin code or card
- / Super elastic tyre
- / Marked solid tyre
- / Left and right rear view mirrors
- / Backup camera
- / Front/rear blue lights
- / Rear working lights
- / Charger (Titan or Schneider)
- / Reverse armrest
- / Hood with a key lock
- / OPS system
- / Lift buffering system
- / Multi way valves
- / Integrated fingertip control system
- / Widened / heightened load backrest
- / Widened fork carriage
- / Other length forks
- / Full free duplex mast
- / Full free triplex mast
- / Sideshifter
- / Other attachments
- / Grammer MSG531 suspension seat
- / Automatic deceleration at turns



Standard specification

- / Lithium packs with low temperature electric heating systems
- / High-power AC drive motor
- / High-power AC pump motor
- / Low noise gear pump
- / Multi-function color screen instrument cluster
- / Large integral rubber pedal pad
- / LED combination headlights, LED rear combination taillights
- / Stamped iron hood
- / Soft landing system
- / SPE power selection
- / Charging muzzle meeting national standards
- / Electronic cooling fan
- / Emergency cut-off switch
- / Reversing buzzer
- / Traction pin
- / Folder
- / Load sensing steering system
- / Duplex mast
- / Tilt cylinder jacket



2.0~2.5t XC series mast specification

Type	Model	Lifting height mm	Lowered overall height mm	Overall height		Free lifting height		Tilting range		Capacity (Mast vertical to ground) Load center@500mm			
				Without backrest mm	With backrest mm	Without backrest mm	With backrest mm	FWD (°)	BWD (°)	Single Tire		Double Tire	
				2.0t kg	2.5t kg	2.0t kg	2.5t kg						
Duplex wide view mast	XPD25M200	2000	1501	2626	3046	140	140	6	6	2000	2500	2000	2500
	XPD25M250	2500	1751	3126	3546	140	140	6	12	2000	2500	2000	2500
	XPD25M270	2700	1851	3326	3746	140	140	6	12	2000	2500	2000	2500
	XPD25M300	3000	2001	3626	4046	140	140	6	12	2000	2500	2000	2500
	XPD25M330	3300	2151	3926	4346	140	140	6	12	2000	2500	2000	2500
	XPD25M350	3500	2251	4126	4546	140	140	6	12	2000	2500	2000	2500
	XPD25M360	3600	2351	4226	4646	140	140	6	12	2000	2500	2000	2500
	XPD25M370	3700	2401	4326	4746	140	140	6	12	2000	2500	2000	2500
	XPD25M400	4000	2601	4626	5046	140	140	6	12	2000	2500	2000	2500
	XPD25M430	4300	2751	4926	5346	140	140	6	6	2000	2500	2000	2500
	XPD25M450	4500	2851	5126	5546	140	140	6	6	2000	2450	2000	2500
	XPD25M470	4700	2951	5326	5746	140	140	6	6	1950	2350	2000	2450
	XPD25M480	4800	3001	5426	5846	140	140	6	6	1950	2350	2000	2450
	XPD25M500	5000	3101	5626	6046	140	140	6	6	1850	2300	1950	2350
XPD25M550	5500	3351	6126	6546	140	140	3	6	1750	2150	1900	2200	
XPD25M600	6000	3601	6626	7046	140	140	3	6	1550	1900	1800	2000	
Duplex full-free mast	XPD25U200	2000	1516	2749	3046	842	470	6	6	2000	2500	2000	2500
	XPD25U250	2500	1766	3173.5	3546	1092	720	6	12	2000	2500	2000	2500
	XPD25U270	2700	1866	3373.5	3746	1192	820	6	12	2000	2500	2000	2500
	XPD25U300	3000	2016	3673.5	4046	1342	970	6	12	2000	2500	2000	2500
	XPD25U330	3300	2166	3973.5	4346	1492	1120	6	12	2000	2500	2000	2500
	XPD25U350	3500	2266	4173.5	4546	1592	1220	6	12	2000	2500	2000	2500
	XPD25U360	3600	2316	4273.5	4646	1642	1270	6	12	2000	2500	2000	2500
XPD25U370	3700	2366	4373.5	4746	1692	1320	6	12	2000	2500	2000	2500	
Triplex full-free mast	XPD25N400	4000	1966	4670.5	5046	1195	920	6	6	2000	2500	2000	2500
	XPD25N430	4300	2066	4970.5	5346	1295	1020	6	6	2000	2450	2000	2500
	XPD25N450	4500	2116	5170.5	5546	1345	1070	6	6	2000	2350	2000	2450
	XPD25N470	4700	2216	5370.5	5746	1445	1170	6	6	1950	2250	2000	2350
	XPD25N480	4800	2266	5470.5	5846	1495	1220	6	6	1950	2250	2000	2350
	XPD25N500	5000	2366	5670.5	6046	1595	1320	6	6	1850	2100	1950	2250
	XPD25N550	5500	2566	6170.5	6546	1795	1520	3	6	1750	2050	1900	2100
	XPD25N600	6000	2816	6670.5	7046	2045	1770	3	6	1550	1850	1800	1950
	XPD25N650	6500	3016	7170.5	7546	2245	1970	3	6	/	/	1550	1800
	XPD25N700	7000	3266	7766	8046	2695	2220	3	6	/	/	1150	1450

With sideshifter minus 200Kg,with integral sideshifter minus 150kg.

3.0~3.5t XC series mast specification

Type	Model	Lifting height mm	Lowered overall height mm	Overall height		Free lifting height		Tilting range		Capacity (Mast vertical to ground) Load center@500mm			
				Without backrest mm	With backrest mm	Without backrest mm	With backrest mm	FWD (°)	BWD (°)	Single Tire		Double Tire	
				3.0t kg	3.5t kg	3.0t kg	3.5t kg						
Duplex wide view mast	XPD35M200	2000	1651	2842	3145	145	150	6	6	3000	3500	3000	3500
	XPD35M250	2500	1901	3342	3645	145	150	6	12	3000	3500	3000	3500
	XPD35M270	2700	2001	3542	3845	145	150	6	12	3000	3500	3000	3500
	XPD35M300	3000	2151	3842	4145	145	150	6	12	3000	3500	3000	3500
	XPD35M330	3300	2301	4142	4445	145	150	6	12	3000	3500	3000	3500
	XPD35M360	3600	2451	4442	4745	145	150	6	12	3000	3500	3000	3500
	XPD35M400	4000	2751	4842	5145	145	150	6	12	3000	3500	3000	3500
	XPD35M430	4300	2901	5142	5445	145	150	6	6	3000	3400	3000	3500
	XPD35M450	4500	3001	5342	5645	145	150	6	6	3000	3300	3000	3400
	XPD35M480	4800	3151	5642	5945	145	150	6	6	2950	3200	3000	3300
	XPD35M500	5000	3251	5842	6145	145	150	6	6	2850	3100	2900	3200
	XPD35M550	5500	3501	6342	6645	145	150	3	6	2670	3000	2750	3100
	XPD35M600	6000	3751	6842	7145	145	150	3	6	2350	2650	2500	2800
	Duplex full-free mast	XPD35U250	2500	1916	3391	3645	1025	771	6	12	3000	3500	3000
XPD35U270		2700	2016	3591	3845	1125	871	6	12	3000	3500	3000	3500
XPD35U300		3000	2166	3891	4145	1275	1021	6	12	3000	3500	3000	3500
XPD35U330		3300	2316	4191	4445	1425	1171	6	12	3000	3500	3000	3500
XPD35U360		3600	2466	4491	4745	1575	1321	6	12	3000	3500	3000	3500
XPD35U400		4000	2716	4891	5145	1825	1571	6	12	3000	3500	3000	3500
XPD35N400		4000	2051	4891	5145	1160	906	6	6	3000	3400	3000	3500
Triplex full-free mast	XPD35N430	4300	2151	5191	5445	1260	1006	6	6	3000	3300	3000	3400
	XPD35N450	4500	2201	5491	5645	1310	1056	6	6	3000	3200	3000	3300
	XPD35N470	4700	2301	5591	5845	1410	1156	6	6	2900	3100	2950	3200
	XPD35N480	4800	2351	5691	5945	1460	1206	6	6	2900	3100	2950	3200
	XPD35N500	5000	2451	5891	6145	1560	1306	6	6	2850	3050	2900	3150
	XPD35N550	5500	2651	6391	6645	1760	1506	3	6	2670	3000	2750	3100
	XPD35N600	6000	2901	6891	7145	2010	1756	3	6	2350	2650	2500	2800
	XPD35N650	6500	3151	7391	7645	2260	2006	3	6	/	/	2200	2400
	XPD35N700	7000	3401	7891	8145	2510	2256	3	6	/	/	1850	2050

With sideshifter minus 200Kg,with integral sideshifter minus 150kg.

XC Series Electric Forklift

Distinguishing mark	HANGCHA GROUP CO.,LTD.						
		CPD20-XD6-SI21*	CPD25-XD6-SI21*	CPD30-XD6-SI21*	CPD35-XD6-SI21*		
1.1	Manufacturer						
1.2	Manufacturers type designation	CPD20-XD6-SI21*	CPD25-XD6-SI21*	CPD30-XD6-SI21*	CPD35-XD6-SI21*		
1.3	Drive: electric (battery or mains), diesel, petrol, fuel gas	Electric	Electric	Electric	Electric		
1.4	Operator type: hand, pedestrian, standing, seated, order-picker	Seated	Seated	Seated	Seated		
1.5	Load capacity/rated load	Q (kg)	2000	2500	3000	3500	
1.6	Load centre distance	c (mm)	500	500	500	500	
1.7	Load distance, centre of drive axle to fork	x (mm)	444	444	477	482	
1.8	Wheelbase	y (mm)	1520	1520	1650	1650	
Weight	2.1	Service Weight	kg	3620	3920	4740	5080
	2.2	Axle loading, laden front/rear	kg	5040/680	5820/700	6745/1095	7800/880
	2.3	Axle loading, unladen front/rear	kg	1620/2000	1670/2250	2010/2730	2100/2980
Tyres, chassis	3.1	Tyres: solid rubber, super elastic, pneumatic, polyurethane		Pneumatic	Pneumatic	Pneumatic	Super elastic
	3.2	Tyre size, front		23×9-10	23×9-10	23×9-10	23×10-12
	3.3	Tyre size, rear		18×7-8	18×7-8	18×7-8	200/50-10
	3.4	Wheels, number front rear (x = driven wheels)		2x/2	2x/2	2x/2	2x/2
	3.5	Tread, front	b10 (mm)	1068	1068	1068	1068
	3.6	Tread, rear	b11 (mm)	960	960	960	960
Dimensions	4.1	Tilt of mast/fork carriage forward/backward	$\alpha/\beta(^{\circ})$	6/12	6/12	6/12	6/12
	4.2	Height, mast lowered	h1 (mm)	2001	2001	2151	2151
	4.3	Free lift	h2 (mm)	140	140	140	145
	4.4	Lift	h3 (mm)	3000	3000	3000	3000
	4.5	Height, mast extended	h4 (mm)	4040	4040	4135	4135
	4.7	Height of overhead guard STD.	h6 (mm)	2100	2100	2100	2100
	4.8	Seat height/stand height	h7 (mm)	1120	1120	1120	1120
	4.9	Coupling height	h10 (mm)	430	430	430	430
	4.10	Overall length	l1 (mm)	3370	3370	3550	3550
	4.11	Length to face of forks	l2 (mm)	2300	2300	2480	2480
	4.12	Overall width	b1 (mm)	1252	1252	1252	1298
	4.13	Fork dimensions	s/e/l (mm)	40/122/1070	40/122/1070	45/122/1070	50/122/1070
	4.14	Fork carriage DIN 15 173 --- ISO 2328, class/type A,B		ISO2328 2A	ISO2328 2A	ISO2328 3A	ISO2328 3A
	4.15	Fork-carriage width	b3 (mm)	1038	1038	1100	1100
	4.16	Distance between fork-arms	b5 (mm)	290/1100	290/1100	290/1100	290/1100
4.17	Ground clearance, laden, below mast	m1 (mm)	120	120	120	120	
4.18	Ground clearance, centre of wheelbase	m2 (mm)	125	125	125	125	
4.19	Aisle width for pallets 1000 x 1200 crossways	Ast (mm)	3734	3734	3950	3955	
4.20	Aisle width for pallets 800 x 1200 Lengthways	Ast (mm)	3934	3934	4150	4155	
4.21	Turning radius	Wa (mm)	2090	2090	2270	2270	
4.22	Internal turning radius	b13 (mm)	655	655	730	730	
Performance Data	5.1	Travel speed, laden/unladen	km/h	14/15	14/15	14/15	14/15
	5.2	Lift speed, laden/unladen	m/s	0.350/0.450	0.3500/0.450	0.330/0.430	0.330/0.430
	5.3	Lowering speed, laden/unladen	m/s	0.450/0.420	0.470/0.420	0.450/0.420	0.470/0.420
	5.4	Drawbar pull, laden/unladen	N	13000/14000	17000/18000	20000/21000	20500/21000
	5.5	Max. Drawbar pull, laden/unladen	N	15000	19000	20000	20000
	5.6	Gradeability, laden/unladen	%	14/15	14/15	14/15	14/15
	5.7	Service brake		Hydraulic	Hydraulic	Hydraulic	Hydraulic
	5.8	Parking brake		Mechanical	Mechanical	Mechanical	Mechanical
Electric engine	6.1	Drive motor rating S2 60 min	kW	11AC	11AC	11AC	11AC
	6.2	Lift motor rating at S3 15%	kW	21AC	21AC	21AC	21AC
	6.3	Battery voltage, Std.	V/Ah	80/228	80/228	80/302	80/302
	6.4	Standard Weight of lithium iron phosphate battery	kg	200	200	240	240
	6.5	Min. battery weight	kg	180	180	230	230
		Max. battery weight	kg	280	280	380	380
	6.6	Type of drive control		MOSFET/AC	MOSFET/AC	MOSFET/AC	MOSFET/AC
	6.7	Manufacturer		INMOTION	INMOTION	INMOTION	INMOTION
6.8	Control Model		ACS80M-35P+ ACS80M-23P	ACS80M-35P+ ACS80M-23P	ACS80L-440C-35P+ ACS80M-23P	ACS80L-440C-35P+ ACS80M-23P	
Addition data	7.1	Operating pressure for attachments	bar	175	175	175	175
	7.2	Oil volume for attachments	l/min	65	65	65	65
	7.3	Hydraulic Tank - capacity (drain & refill)	liter	28	28	28	28
	7.4	Sound level at the driver's ear according to EN / DIN 12 053	dB (A)	75	75	75	75
	7.5	Towing coupling, type DIN		Φ25 Pin	Φ25 Pin	Φ25 Pin	Φ25 Pin

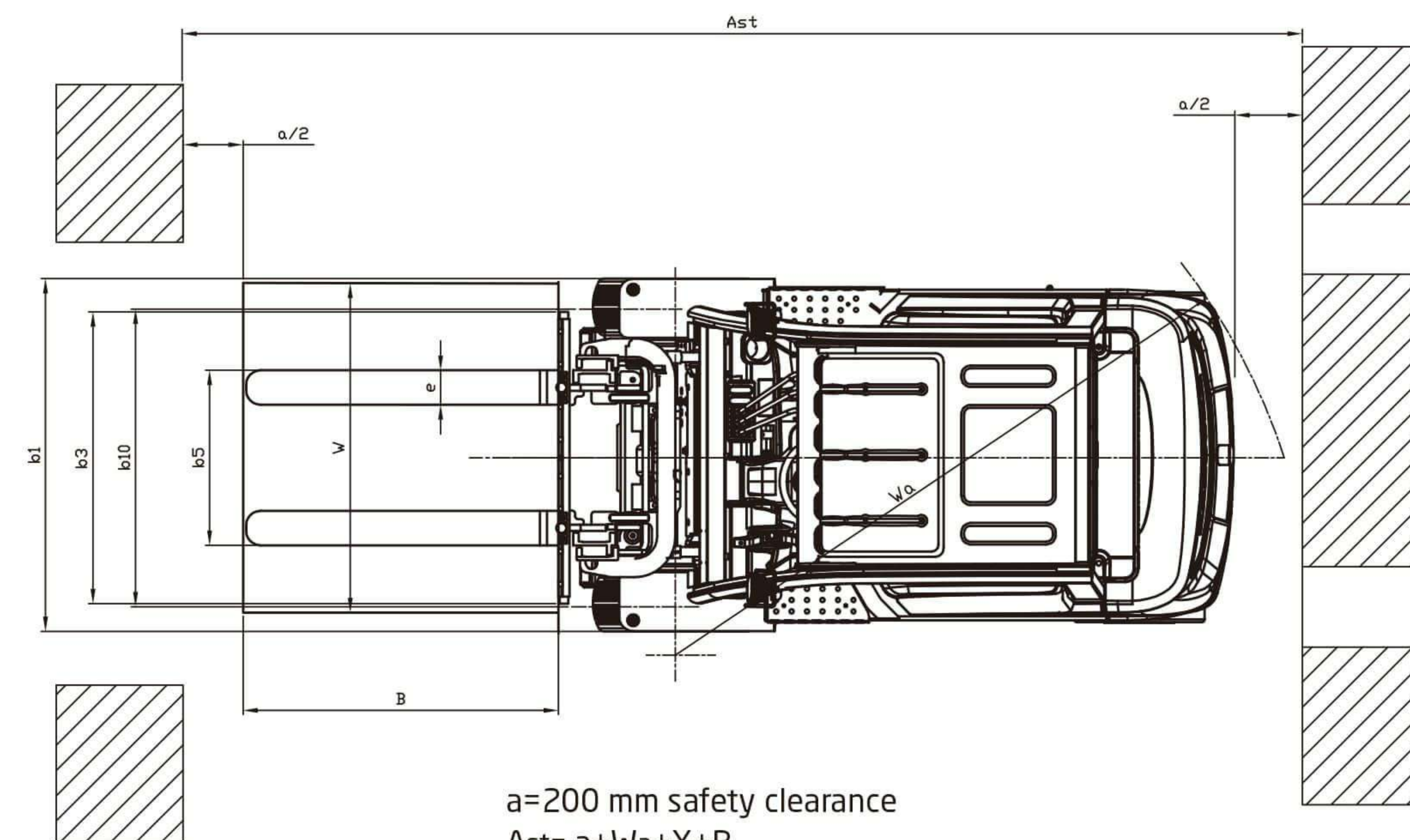
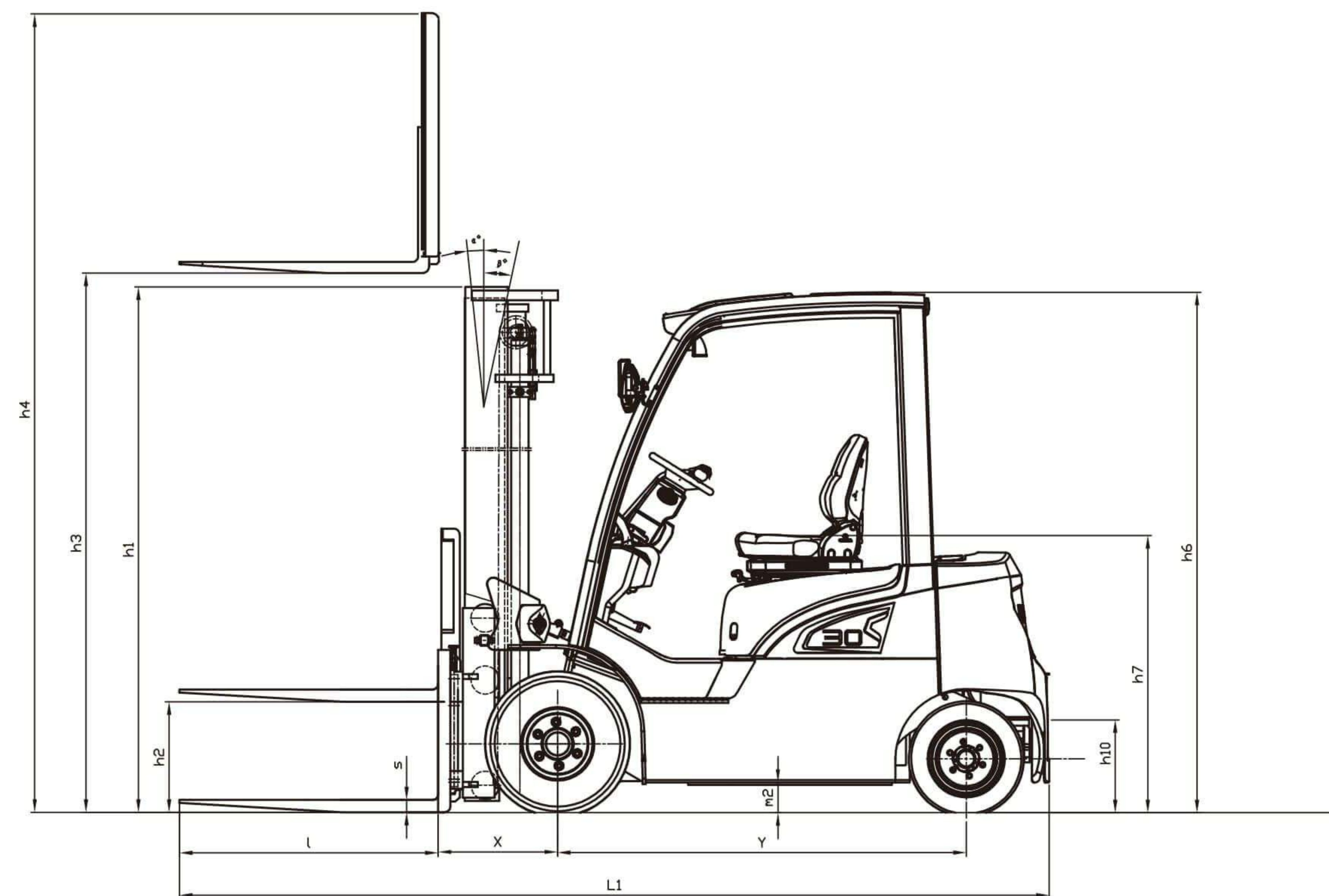

a=200 mm safety clearance
Ast= a+Wa+X+B

3M duplex mast

